

SUPER LARGE SIZED BUTTERFLY VALVE



BS Series

超大型旋轉凡而

BS300

Size: Ø700(28") ~ Ø1200(48")

MATERIAL: UPVC, PP, CPVC, PPG, PVDF

**MODEL: Gear operated type(齒輪式), Chaining type(鏈條式)
Hydraulic type(油壓式), Pneumatic type(氣壓式)**

FEATURES:

- Fullport allowing max. fluid flow. 全口徑、流量足。
- ECONOMIC EQUIPMENT: Fluid control plate concealed in piping system, space saved, 設備經濟、控制流量的活版、隱藏於管路中、佔管路配置極小的空間。
- EASY OPERATION-90° open and close, long duration, 操作簡便, 90° 開關使用壽命長。
- WIDE APPLICATION RANGE-Acid & alkali resistance, anti-corrosion, and suitable for fluid and air use. 用途極廣, 可耐強酸, 強鹼並適用於液體及氣體。

● MATERIALS OF CONSTRUCTION

No.	Parts	Pcs.	Materials	No.	Parts	Pcs.	Materials
1	Body	1	PP, PPG	14	Bearing	1	STEEL
2	Seat	1	EPDM, VITON, NBR, HYPALON	15	Adjustable Bolt	2	STEEL
3	Disc	1	UPVC, PP, CPVC, PPG, PVDF	16	WORM SHAFT	1	STEEL
4	Disc O'ring(A)	2	EPDM, VITON	17	Set Pin	1	K7
5	Disc O'ring(B)	2	EPDM, VITON	18	Hand Wheel	1	CAST IRON
6	Stem	1	SUS410, SUS304, SUS316	19	Tightening Bolt	4	SUS304
7	Stem O'ring	2	EPDM, VITON	20	Bearing	4	COPPER
8	Gear Box	1	CAST IRON	21	SPUR GEAR BODY	1	CAST IRON
9	Gear Box Cap	1	CAST IRON	22	SPUR GEAR	1	STEEL
10	Side Cap	1	CAST IRON	23	SPUR GEAR SHAFT	1	STEEL
11	Indicator Plate	1	CAST IRON	24	SPUR GEAR COVER	1	CAST IRON
12	Gear	1	DUCTILE IRON	25	BOLT	6	STEEL
13	Oil Seal	1	EPDM				

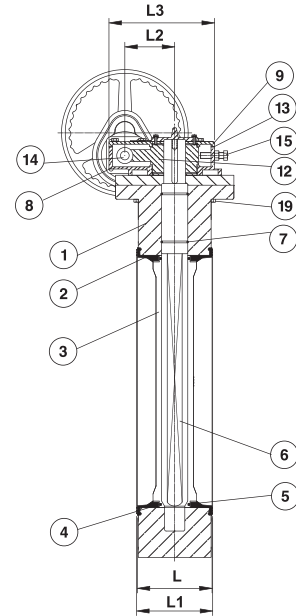
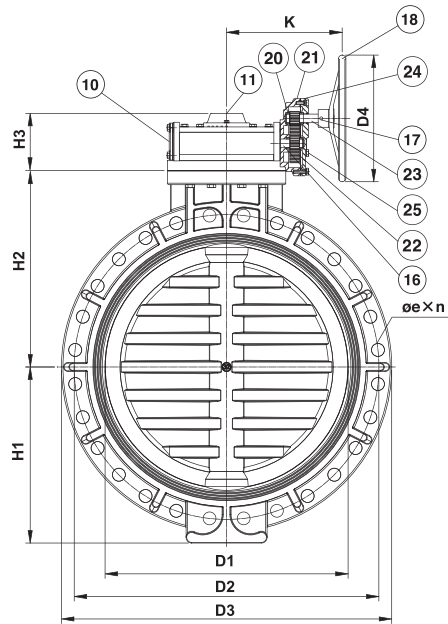

DN700~DN1200

● TORQUE VALUES (1Kgf/m=9.8 N.m)

BF-V'S Size	700(28")	800(32")	900(36")	1000(40")	1200(48")
Torque Under Without Any Water Pressure (Kgf/m)	4480	5850	7400	10300	10300

● DIMENSIONS TABLE

JIS													Unit: mm	
Nom. size DN(inch)	D1	D2	D3	n	e	H1	H2	H3	K	D4	L	L1	Test Press (kgf/cm ²)	Working Press (kgf/cm ²)
700(28")	680	840	942	24	33	498	563	138	325	356	203	210	4	3
800(32")	780	950	1068	28	33	503	630	132	372	406	241	248	4	3
900(36")	870	1050	1185	28	33	621	694	132	372	406	241	248	4	3
1000(40")	970	1160	1290	28	39	683	762	210	471	508	300	307	4	3
1200(48")	1170	1380	1512	32	39	776	876	210	471	508	300	307	3	2

ANSI													Unit: inch	
Nom. size DN(inch)	D1	D2	D3	n	e	H1	H2	H3	K	D4	L	L1	Test Press (lb/in ²)	Working Press (lb/in ²)
700(28")	26.77	33.99	37.09	24	1.37	19.60	22.17	5.40	12.57	14.02	7.99	8.26	60	45
800(32")	30.70	38.50	42.05	24	1.61	19.80	24.80	5.18	14.59	15.98	9.48	9.76	60	45
900(36")	34.25	42.75	46.65	32	1.62	24.45	27.32	5.18	14.59	15.98	9.48	9.76	60	45
1000(40")	38.18	46.25	50.88	32	1.62	26.89	30.00	8.27	18.54	20	11.81	12.08	60	45
1200(48")	46.06	56.00	59.52	44	1.62	30.55	34.48	8.27	18.54	20	11.81	12.08	45	30

DIN													Unit: mm	
Nom. size DN(inch)	D1	D2	D3	n	e	H1	H2	H3	K	D4	L	L1	Test Press (bar)	Working Press (bar)
700(28")	680	840	942	24	30	498	563	138	325	356	203	210	4	3
800(32")	780	950	1068	24	33	503	630	132	372	406	241	248	4	3
900(36")	870	1050	1185	28	33	621	694	132	372	406	241	248	4	3
1000(40")	970	1175	1290	28	36	683	762	210	471	508	300	307	4	3
1200(48")	1170	1380	1512	32	39	776	876	210	471	508	300	307	3	2

※ 法蘭長度公差依據 EN558-1:1995 標準

※ L長度為安裝後建議參考值

※ Standard dimensions based on PP material.

The flanged length tolerance is according to EN558-1:1995.

※ L : The suggested length of the valve as installed on pipeline.